

特别申明：本资料数据由本公司负责解释，如有参数变更，恕不另行通知。

Special statement: The company is responsible for the interpretation of this information and data, if the parameters are changed, without prior notice.



Sync with the world
Create a model for

China

—
与世界同步
创中国典范



节能低碳，科学发展

Energy Saving And Low Carbon,
Scientific Development

浙江浙東閥門股份有限公司
ZHEJIANG ZHEDONG VALVE CORP., LTD.

地址/ADD

浙江省永嘉县瓯北镇东瓯工业园
Dongou Industrial Park, Oubei Town, Yongjia County, Zhejiang Province.

电话/TEL

0577-67996666 67353521

传真/FAX

0577-67353078

网址/WBE

www.zhedong-valve.com

邮箱/E-mail

pans@zhedong-valve.com



浙江浙東閥門股份有限公司

ZHEJIANG ZHEDONG VALVE CORP., LTD.

浙東閥門股份

PANS®



ZHEDONG VALVE

产品选型手册
PRODUCT SELECTION GUIDE

ABOUT US

关于我们



浙江浙东阀门股份有限公司创办于1985年，拥有浙江浙东与上海浙东两大品牌。注册总资金10080万元，总占地面积60000m²，建筑面积48000m²。注册商标有“”和“**PANS**”，其中商标在国际注册9个国家，是“浙江省著名商标”。前身为浙东高中压阀门有限公司，由于企业发展规划进行股改原浙东高中压阀门有限公司，上海浙东阀门集团所有业务纳入新公司浙江浙东阀门股份有限公司运营管理。

公司是集设计、研发、生产、国内外销售和技术服务为一体的科技型、外向型、规模型高中压阀门专业化制造企业；拥有各类数控加工中心等主要精良装备400余台（套），现代化检验、检测设备200余台（套）；是高新技术企业、“省科技型企业”、“优秀创新型企业”、“温州中小企业30强”、“中国泵阀之乡30强”、省、市“成长型企业”、国家“出口产品绿色通道企业”。



主导产品为公称口径：DN15mm~DN1200mm (1/2"~48")；公称压力：PN1.0Mpa~42.0Mpa (150Lb~2500Lb)；工作温度-101℃~+800℃的闸阀、截止阀、止回阀、球阀、旋塞阀、波纹管截止阀、均通过国家“TS” A级认证以及美国石油协会API 6D认证，拥有省级企业技术中心，员工860余名，科技人员260余名。其中高级工程师（含教授级）、工程师等90余名；获得国家发明等授权专利近10项；省重点高新技术产品等10余项；省科技成果7项；科技进步奖4项；产品获得“温州名牌产品”称号。

公司是中国通用机械协会理事、永嘉泵阀协会副会长单位；中国化工装备总公司泵阀定点生产企业；中石油一级供应网络成员；中石化优秀供应商；国电力电站配件供应网络成员；商务部“AAA诚信企业”；中国泵阀之乡“明星企业”；永嘉“巨龙企业”；“纳税大户”；“重合同守信用单位”；工行温州分行“AAA级信用”企业；中燃气会员单位；中石化设工协会会员单位；中质协会会员单位。

严格按照国际ISO、美国API、ANSI、英国BS、德国DIN、法国NF、日本JIS、JPI、俄罗斯ГОСТ、中国GB、JB以及企业标准组织生产并可根用户特殊要求设计、冶炼和制造；多年来产品质量经国家质监总局和省质监局10多次抽查和检查均合格，被评为“全国产品质量监督抽查合格”单位，证明产品质量长期稳定可靠；广泛应用于国内外石油天然气、石化、钢铁、冶金、电站、化工、制药、水力、液化气管道、建筑、消防等行业管网系统的阀门配套；产品畅销全国各地，并远销美洲、加拿大、欧盟、独联体国家、中东、东南亚等30多个国家和地区，受到用户的广泛青睐和赞誉，年出口额在同行名列前茅，在国内外赢得了良好的口碑，市场前景十分看好。

公司较早通过，特种设备（压力管道）制造（TS）A级，环境体系认证ISO9001，ISO14001、ISO45001、美国石油协会API 6D、欧盟CE、认证；标准化良好行为AA级、计量检测体系市级和采用国际标准合格确认；是首批中国特种设备（压力管道）制造（TS）许可转换单位。

我们向国内外新老客户郑重承诺：提供质量上乘、货真价实、100%合格的产品，目标是创建国际阀门品牌；以优良的服务，提供最有价值的产品，目的是与国内外新老客户一起实现双赢！

Zhejiang Zhedong Valve Corp., Ltd., founded in 1985, owns two major brands, Zhejiang Zhedong and Shanghai Zhedong. The total registered capital is 100.8 million yuan, with a total area of 60,000m² and a construction area of 48,000m². The registered trademarks are "" and "**PANS**", of which the trademark is registered in  9 countries internationally, and it is a "Famous Trademark in Zhejiang Province". Formerly known as Zhedong High and Medium Pressure Valve Co., Ltd., due to the corporate development plan, the original Zhedong High and Medium Pressure Valve Co., Ltd. was reformed, and all the business of Shanghai Zhedong Valve Group was incorporated into the operation and management of the new company, Zhejiang Zhedong Valve Co., Ltd.

The company is a high-tech, export-oriented and large-scale high- and medium-pressure valve specialized manufacturing enterprise integrating design, research and development, production, domestic and foreign sales and technical services; it has more than 400 sets (sets) of major sophisticated equipment such as various CNC machining centers, more than 200 sets (sets) of modern inspection and testing equipment; it is a high-tech enterprise, "provincial science and technology enterprise", "excellent innovative enterprise", "Top 30 Small and Medium Enterprises in Wenzhou", "Top 30 Hometown of Pumps and Valves in China", Provincial and municipal "growth-oriented enterprises" and national "green channel enterprises for export products".

The main products are nominal diameter: DN15mm~DN1200mm (1/2"~48"); nominal pressure: PN1.0Mpa~42.0Mpa (150Lb~2500Lb); gate valve, globe valve, working temperature -101℃~+800℃, Check valves, ball valves, plug valves, and bellows globe valves have all passed the national "TS" A-level certification and the American Petroleum Institute API 6D certification. It has a provincial-level enterprise technology center with more than 860 employees and more than 260 scientific and technological personnel. Among them, there are more than 90 senior engineers (including professor-level) and engineers; nearly 10 authorized patents for national inventions; more than 10 provincial key high-tech products; 7 provincial scientific and technological achievements; 4 scientific and technological progress awards; Wenzhou Famous Brand Product" title.

The company is a director of China General Machinery Association and a vice-chairman unit of Yongjia Pump and Valve Association; a designated pump and valve manufacturer of China National Chemical Equipment Corporation; a member of the first-class supply network of PetroChina; an excellent supplier of Sinopec; a member of the State Power Station Parts Supply Network; Ministry of Commerce "AAA Integrity Enterprise"; "Star Enterprise" in China's Hometown of Pumps and Valves; "Dragon Enterprise" in Yongjia; "Large Tax Payer"; Member unit of Sinopec Engineering Association; member unit of China Quality Association.

Strictly organize production in accordance with international ISO, American API, ANSI, British BS, German DIN, French NF, Japanese JIS, JPI, Russian ГОСТ, Chinese GB, JB and enterprise standards, and can design, smelt and manufacture according to the special requirements of users; The product quality has passed more than 10 random inspections and inspections by the State General Administration of Quality Supervision and the Provincial Quality Supervision Bureau, and has been rated as a "National Product Quality Supervision and Sampling Inspection Qualified" unit, which proves that the product quality is stable and reliable for a long time; it is widely used in domestic and foreign oil and gas, petrochemical, steel, metallurgy, power station, chemical, pharmaceutical, hydraulic, liquefied gas pipeline, construction, fire protection and other industries pipe network system valve matching; products sell well all over the country, and exported to the Americas, Canada, the European Union, the CIS countries, the Middle East, More than 30 countries and regions such as Southeast Asia are widely favored and praised by users. The annual export volume ranks among the best in the industry. It has won a good reputation at home and abroad, and the market prospect is very promising.

The company passed earlier, special equipment (pressure pipeline) manufacturing (TS) grade A, environmental system certification ISO9001, ISO14001, ISO45001, American Petroleum Institute API 6D, EU CE, certification; standardization good behavior AA grade, measurement and testing system municipal level and Adopting international standard qualification confirmation; it is the first batch of Chinese special equipment (pressure pipeline) manufacturing (TS) license conversion units.

We solemnly promise to new and old customers at home and abroad: to provide high-quality, genuine and 100% qualified products, the goal is to create an international valve brand; to provide the most valuable products with excellent service, the goal is to cooperate with new and old customers at home and abroad. Achieve a win-win situation!

B

CERTIFICATIONS 资质证书

公司获得的资质和荣誉，是对企业过去取得成绩的肯定，也是对企业创造明日辉煌的鼓舞和鞭策！向新的台阶迈进，是团队的顽强拼搏，永不停歇的信念！

The qualifications and honors obtained by the company are the affirmation of the company's achievements in the past, and also the encouragement and encouragement for the company to create a brilliant future! To advance to a new level is the tenacious struggle of the team and the belief that will never stop!



O

ORGANIZATION 组织机构



沟通无限制与同事、与上级、与下级、与客户、甚至与竞争对手都要倡导沟通。

浙东企业要实现无限制的沟通，任何一个员工都可以直接找到领导进行沟通，领导也可以找任何一个员工进行对等交流。

Unrestricted communication. Advocate communication with colleagues, superiors, subordinates, customers, and even competitors.

To realize unrestricted communication in Zhedong enterprises, any employee can directly find the leader for communication, and the leader can also find any employee for peer-to-peer communication.



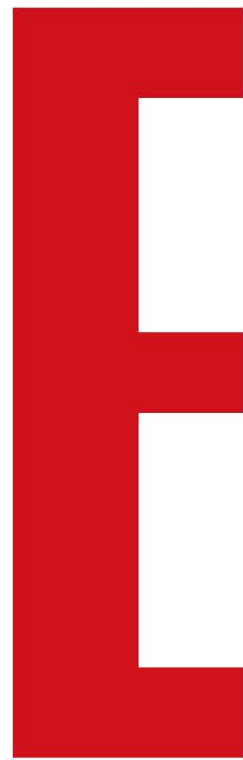

PRODUCT DEVELOPMENT 产品研发



秉承重视技术创新的优良传统，为了进一步加大管道理论研究和技术开发力度，为了持续开发新产品，提高产品的技术含量和附加值，企业投入巨资建设研发中心，保持企业产品品质领先行业水平。

Adhering to the fine tradition of attaching importance to technological innovation, in order to further increase the strength of pipeline theoretical research and technology development, in order to continuously develop new products and improve the technical content and added value of products, the company has invested heavily in the construction of R&D centers to maintain the company's product quality leading the industry level.

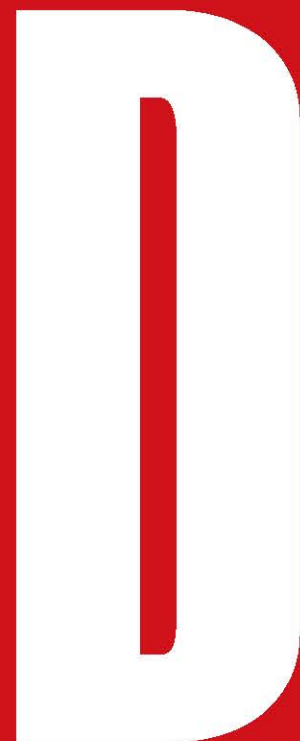

EXCELLENT TEAM 优秀团队

一个完整的销售流程应当至少包括售前服务、售中服务、与售后服务三个部分。在当前市场环境下，售后服务被放到特别突出的位置，很少有人研究分析售中的售前服务问题。在整个营销和销售系统中，售前服务是营销和销售之间的纽带，作用至关重要，不可忽视。

浙东企业，在顾客未接触产品时协助顾客做好工程规划和系统需求分析，使我们的产品能够最大限度的满足顾客需求，同时也使顾客的投资发挥出最大的综合经济效益。

A complete sales process should include at least three parts: pre-sales service, in-sale service, and after-sales service. In the current market environment, after-sales service has been placed in a particularly prominent position, and few people have studied and analyzed the pre-sale service issues in sales. In the entire marketing and sales system, pre-sales service is the link between marketing and sales. Its role is very important and cannot be ignored.

Zhedong enterprises assist customers in engineering planning and system demand analysis when they are not in contact with products, so that our products can meet customer needs to the greatest extent, and at the same time, customers' investment can maximize comprehensive economic benefits.

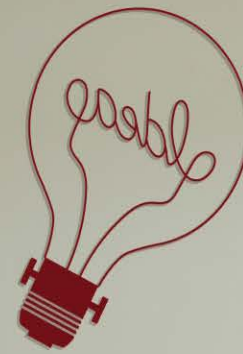

培养科学研究精神 提高实践创新能力

Cultivate the spirit of scientific research
Improve practical innovation ability





为了提供高品质产品，公司配备了先进的检测设备以及完善的检测流程，建立了一支严格要求的品质管理队伍，实现了从原材料检测，生产过程检测，产品及应用全过程的质量控制。

In order to provide high-quality products, the company is equipped with advanced testing equipment and a complete testing process, and has established a strict quality management team to achieve quality control from raw material testing, production process testing, product and application process.

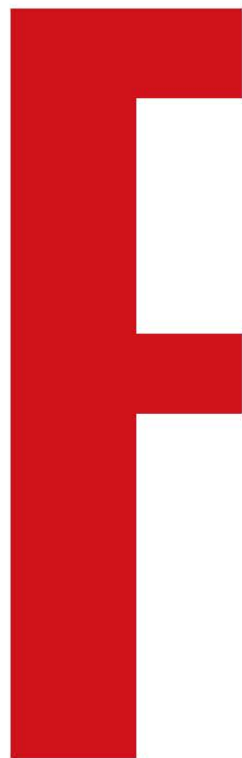

PRODUCT TESTING 产品检测





SOPHISTICATED EQUIPMENT

精良设备

企业拥有世界先进的生产设备，运用崭新的工业概念及强大的技术力量，生产出符合国际标准的高品质产品。

精良的现代化数控加工装备和独特的技术工艺实现了浙东企业的完美呈现，自主技术开发的高品质产品充分体现了浙东企业对品牌国际化战略的不懈追求。

The company has the world's most advanced production equipment, and uses new industrial concepts and strong technical force to produce high-quality products that meet international standards.

Sophisticated modern CNC machining equipment and unique technical processes have realized the perfect presentation of Zhejiang eastern enterprises.

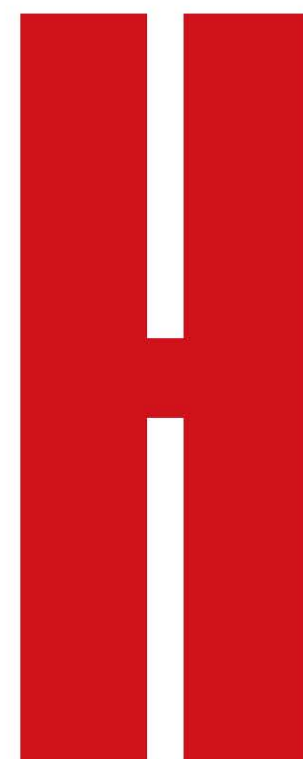

PANS[®]
ZHEONG VALVE

PRODUCT DISPLAY

产品展示

我们追求生产的精确性，精细化。不断完善自己的精益生产方式，包括每一个零部件，都严格按标准精心打造，确保产品的高品质。

We pursue the precision and refinement of production. Constantly improve its own lean production method, including every component, are carefully built in strict accordance with the standards to ensure the high quality of products.

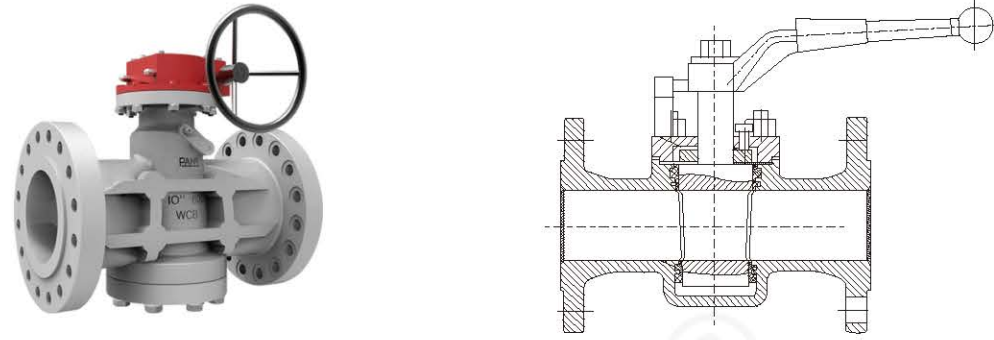

◎主要性能规范 Main performance specification

设计规范 Design code	结构长度 Structural length	连接法兰 Connecting flange	试验与检验 Test and inspection	产品标识 Product identification	供货规范 Supply specification
API 599	ASME B16.10	ASME B16.5	API 598	MSS SP-25	API 599
DIN3352/BS 5353	DIN 3202	DIN 2501	DIN 320	DIN 3211	DIN 3352

◎主要零部件材质 Materials of main parts

零件名称 Part name	材料 Material
阀体 Body	ASTM A216 WCB ASTM A351-CF8,CF8M,CF3,CF3M
卡套 Sleeve	PTFE
塞子 Stopper	ASTM A182-Gr.F6a ASTM A182-F22 ASTM A182-F304,F316,F321,F304L,F316
垫片 Gasket	柔性石墨+不锈钢 Flexible graphite + stainless steel, PTFE
调整垫 Adjustment mats	ASTM A182-Gr.F6a ASTM A182-F22 ASTM A182-F304,F316,F321,F304L,F316
阀盖 Bonnet	ASTM A216-WCB ASTM A351-CF8,CF8M,CF3,CF3M
调整螺栓 Adjusting bolt	ASTM A193-B7,A193-B8,A193-B8M
六角螺母 Hex nuts	ASTM A194-2H,A194-8,A194-8M
螺栓 Bolt	ASTM A193-B7,A193-B8,A193-B8M
手柄 Handle	ASTM A105-WCB

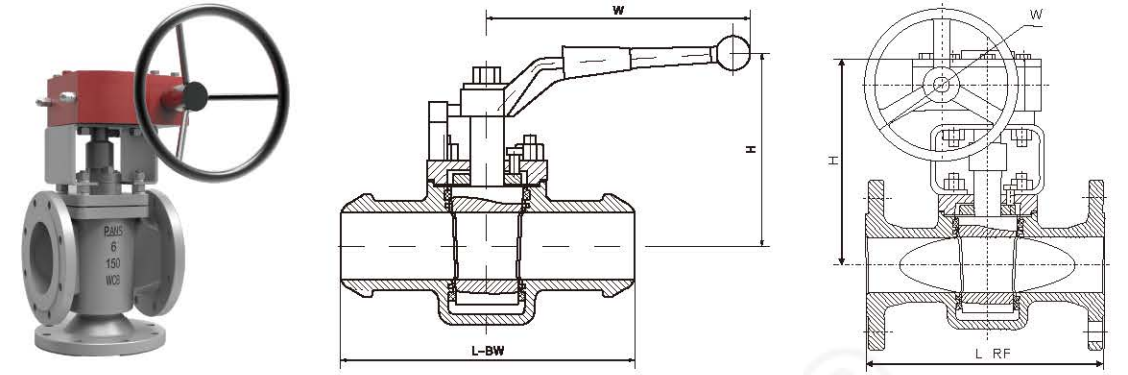

◎主要外形尺寸和连接尺寸 Main shape size and connection size

单位(Unit): mm

型号 Model		150Lb														
DN	mm	15	20	25	32	40	50	65	80	100	125	150	200	250	300	350
NPS	in	1/2	3/4	1	1 1/4	1 1/2	2	2 1/2	3	4	5	6	8	10	12	14
L-RF		108	117	127	140	165	178	190	203	229	254	267	292	330	356	381
L-BW		152	178	203	216	229	267	305	330	356	381	394	457	533	610	686
H		110	115	115	135	140	150	165	180	380	460	520	580	620	680	760
W		175	175	175	220	280	305	350	405	300	300	320	320	350	380	450
重量Weight(kg)		8.5	9.5	10.5	12	14	18	22	26	40	60	70	130	219	381	570

型号 Model		300Lb														
DN	mm	15	20	25	32	40	50	65	80	100	125	150	200	250	300	350
NPS	in	1/2	3/4	1	1 1/4	1 1/2	2	2 1/2	3	4	5	6	8	10	12	14
L-RF		140	152	165	178	190	216	241	283	305	381	403	419	457	502	762
L-BW		152	178	203	216	229	267	305	330	356	381	457	521	559	635	762
H		110	115	115	135	140	150	165	180	380	460	520	580	620	680	760
W		175	175	175	220	280	305	350	405	300	300	320	320	350	380	450
重量Weight(kg)		9.5	10.5	12	14	16	20	24	29	53	75	85	185	230	390	550

型号 Model		600Lb														
DN	mm	15	20	25	32	40	50	65	80	100	125	150	200	250	300	350
NPS	in	1/2	3/4	1	1 1/4	1 1/2	2	2 1/2	3	4	5	6	8	10	12	14
L-RF·BW		165	190	216	229	241	292	330	356	432	508	559	660	787	838	889
H		110	115	115	135	140	150	165	180	380	460	520	580	620	680	760
W		175	175	175	220	280	305	350	405	300	300	320	320	350	380	450
重量Weight(kg)		11	13	17	20	23	27	31	36	72	98	141	245	330	515	710

型号 Model		900Lb														
DN	mm	15	20	25	32	40	50	65	80	100	125	150	200	250	300	350
NPS	in	1/2	3/4	1	1 1/4	1 1/2	2	2 1/2	3	4	5	6	8	10	12	14
L-RF·BW		229	229	254	279	305	368	419	381	457	559	610	737	838	965	1029
H		110	115	115	135	140	150	165	180	380	460	520	580	620	680	760
W		175	175	175	220	280	305	350	405	300	300	320	320	350	380	450
重量Weight(kg)		13	16	21	24	28	32	40	47	91	117	165	285	420	610	860

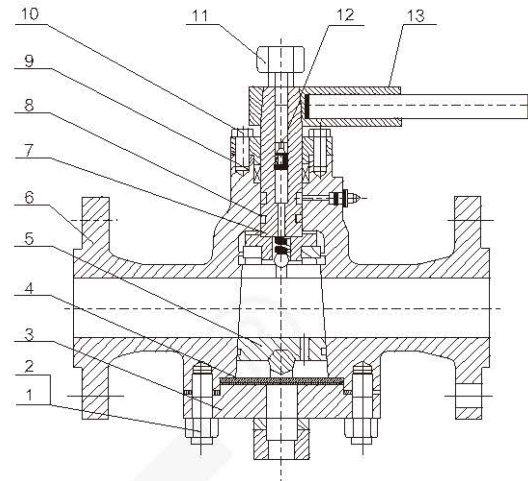

◎主要零件材料 Material for main parts

序号No.	零件名称 Part Name	材料 Material
1	双头螺栓 Stud	ASTM A193-B7、A193-B8、A193-B8M
2	六角螺母 Hex nuts	ASTM A194-2H、A194-8、A194-8M
3	阀盖 Bonnet	ASTM A216-WCB ASTM A351-CF8、CF8M、CF3、CF3M
4	垫片 Gasket	柔性石墨+不锈钢 Flexible graphite + stainless steel, PTFE
5	塞子 Stopper	ASTM A182-Gr.F6a ASTM A182-F22 ASTM A182-F304,F316,F321,F304,F316L
6	阀体 Body	ASTM A216-WCB ASTM A351-CF8,CF8M,CF3,CF3M
7	阀杆 Stem	ASTM A182-Gr.F6a ASTM A182-F22 ASTM A182-F304,F316,F321,F304,F316L
8	"O" 型圈 "O" ring	丁晴橡胶 NBR
9	填料 Packing	柔性石墨 Flexible graphite、PTFE
10	填料压盖 Gland	ASTM A216-WCB ASTM A351-CF8,CF8M,CF3,CF3M
11	加油嘴 Refueling nozzle	
12	止回阀 Check	
13	手柄 Handle	ASTM A47-32510、A216WCB

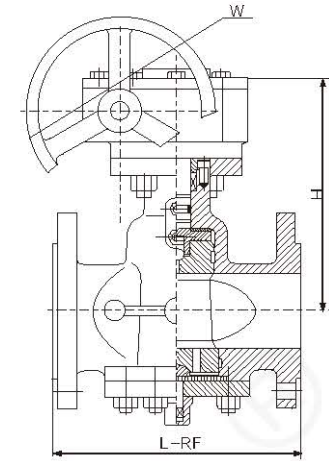

◎规格主要尺寸 Size Main Dimensions

型号 Model		150Lb														
DN	mm	15	20	25	32	40	50	65	80	100	125	150	200	250	300	350
NPS	in	1/2	3/4	1	1 1/4	1 1/2	2	2 1/2	3	4	5	6	8	10	12	14
L-RF		108	117	127	140	165	178	190	203	229	254	267	292	330	356	381
L-BW		152	178	203	216	229	267	305	330	356	381	394	457	533	610	686
H		180	180	285	200	210	215	250	270	300	340	365	400	450	510	590
W		400	400	500	500	600	600	820	820	300	300	320	320	350	380	380
重量Weight(kg)		10	12	14	17	19	21	29	33	48	75	98	125	171	230	370

型号 Model		300Lb														
DN	mm	15	20	25	32	40	50	65	80	100	125	150	200	250	300	350
NPS	in	1/2	3/4	1	1 1/4	1 1/2	2	2 1/2	3	4	5	6	8	10	12	14
L-RF		140	152	165	178	190	216	241	283	305	381	403	419	457	502	762
L-BW		152	178	203	216	229	267	305	330	356	381	457	521	559	635	762
H		180	180	185	200	210	215	250	270	300	340	365	400	450	510	590
W		400	400	500	600	600	820	1000	1000	300	300	320	320	350	380	380
重量Weight(kg)		12	14	16	19	21	31	36	61	86	130	190	255	380	560	

型号 Model		600Lb														
DN	mm	15	20	25	32	40	50	65	80	100	125	150	200	250	300	350
NPS	in	1/2	3/4	1	1 1/4	1 1/2	2	2 1/2	3	4	5	6	8	10	12	14
L-RF·BW		165	190	216	229	241	292	330	356	432	508	559	660	787	838	889
H		180	180	185	200	210	215	250	270	300	340	520	400	450	510	590
W		400	400	500	500	600	600	820	820	300	300	320	320	350	380	380
重量Weight(kg)		14	16	18	20	24	29	35	47	91	129	210	320	660	920	1250

型号 Model		900Lb														
DN	mm	15	20	25	32	40	50	65	80	100	125	150	200	250	300	350
NPS	in	1/2	3/4	1	1 1/4	1 1/2	2	2 1/2	3	4	5	6	8	10	12	14
L-RF·BW		229	229	254	279	305	368	419	381	457	559	610	737	838	965	1029
H		180	180	185	200	210	215	250	270	300	340	365	400	450	510	590
W		400	400	500	600	600	820	1000	1000	300	300	320	320	350	380	380
重量Weight(kg)		17	29	21	24	30	37	44	65	110	160	255	380	810	1050	1460

注：四寸及以上为蜗轮操作 Note: The four-inch and above worm gear operator

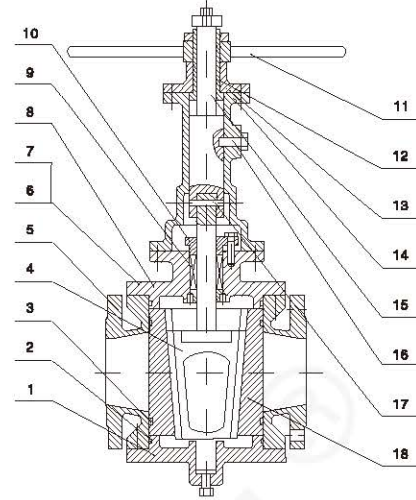

◎主要零件材料 Material for main parts

序号NO.	名称 Part name	材质 Material
1	下盖 Bottom	ASTMA216-WCB ASTM A351-CF8,CF8M,CF3,CF3M
2	O型圈 Oring	丁腈橡胶 NBR、PTFE
3	密封圈 Sealing ring	氟橡胶 Viton、PTFE
4	塞子 Plug	ASTM A182-Gr.F6a ASTM A182-F22 ASTM A351-CF8,CF8M,CF3,CF3M
5	阀体 Body	ASTMA216-WCB ASTM A351-CF8,CF8M,CF3,CF3M
6	螺栓 Bolt	ASTM A193-B7,A193-B8,A193-8M
7	六角螺母 Nut	ASTMA194-2H,A194-8,A194-8M
8	阀盖 Cover	ASTMA216-WCB ASTM A351-CF8,CF8M,CF3,CF3M
9	填料 Packing	柔性石墨+不锈钢 Flexible graphite+stainless steel、PTFE
10	填料压盖 Gland	ASTMA216-WCB ASTM A351-CF8,CF8M,CF3,CF3M
11	手轮 Handwheel	ASTM A536 Gr.60-40-18、A216-WCB
12	阀杆螺母 Yoke nut	铜合金 ZQA19-4
13	阀杆螺母套 Yoke nut bushing	ASTMA216-WCB ASTM A351-CF8,CF8M,CF3,CF3M
14	支架 Yoke	ASTMA216-WCB ASTM A351-CF8,CF8M,CF3,CF3M
15	阀杆 Stem	ASTM A182-Gr.F6a ASTM A182-F22 ASTM A351-CF8,CF8M,CF3,CF3M
16	导向螺栓 Guiding stud	ASTM A182-Gr.F6a ASTM A182-F22 ASTM A351-CF8,CF8M,CF3,CF3M
17	销 Pin	ASTM A182-Gr.F6a ASTM A182-F22 ASTM A351-CF8,CF8M,CF3,CF3M
18	阀片 Disc	ASTM A182-Gr.F6a ASTM A182-F22 ASTM A351-CF8,CF8M,CF3,CF3M

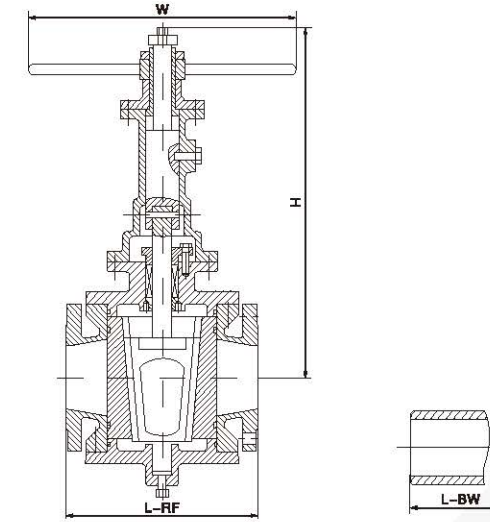

◎主要外形和连接尺寸 Main outline and connecting dimensions

单位Unit: mm

型号 Model	ZDAOX43-150															
压力等级 Pressure	150LB															
口径 Size	mm	15	20	25	32	40	50	65	80	100	125	150	200	250	300	350
	in	1/2	3/4	1	1 1/4	1 1/2	2	2 1/2	3	4	5	6	8	10	12	14
L-RF	108	117	127	140	165	178	190	203	229	254	267	292	330	305	381	
L-BW	152	178	203	216	229	267	305	330	356	381	394	457	533	610	686	
H	230	260	300	340	380	435	460	490	525	570	625	700	780	870	980	
W	120	140	140	180	200	220	260	280	300	340	400	450	450	500	500	
重量 (KG) Weight	10	12	18	25	29	34	39	50	65	95	135	275	275	350	605	
型号 Model	ZDAOX43-300															
压力等级 Pressure	300LB															
口径 Size	mm	15	20	25	32	40	50	65	80	100	125	150	200	250	300	350
	in	1/2	3/4	1	1 1/4	1 1/2	2	2 1/2	3	4	5	6	8	10	12	14
L-RF	140	152	165	178	190	216	241	283	305	381	403	419	457	502	762	
L-BW	152	178	203	216	229	267	305	330	356	381	457	521	559	635	762	
H	230	260	300	240	380	435	460	490	525	570	625	700	780	870	980	
W	120	140	140	180	200	220	260	280	300	340	400	450	450	500	500	
重量 (KG) Weight	11	13	20	27	31	37	44	60	82	115	165	225	305	405	650	
型号 Model	ZDAOX43-600															
压力等级 Pressure	600LB															
口径 Size	mm	15	20	25	32	40	50	65	80	100	125	150	200	250	300	350
	in	1/2	3/4	1	1 1/4	1 1/2	2	2 1/2	3	4	5	6	8	10	12	14
L-RF·BW	165	190	216	229	241	292	330	356	432	508	559	660	787	838	889	
H	230	260	300	340	380	435	460	490	525	570	625	700	780	870	980	
W	120	140	140	180	200	220	260	280	300	340	400	450	450	500	500	
重量 (KG) Weight	13	15	22	29	34	41	54	68	99	128	191	258	430	650	870	
型号 Model	ZDAOX43-900															
压力等级 Pressure	900LB															
口径 Size	mm	15	20	25	32	40	50	65	80	100	125	150	200	250	300	350
	in	1/2	3/4	1	1 1/4	1 1/2	2	2 1/2	3	4	5	6	8	10	12	14
L-RF·BW	229	229	254	279	305	368	419	381	457	559	610	737	838	965	1029	
H	230	260	300	340	380	435	460	490	525	570	625	700	780	870	980	
W	120	140	140	180	200	220	260	280	300	340	400	450	450	500	500	
重量 (KG) Weight	15	19	24	32	38	47	62	75	115	147	220	379	490	720	1020	

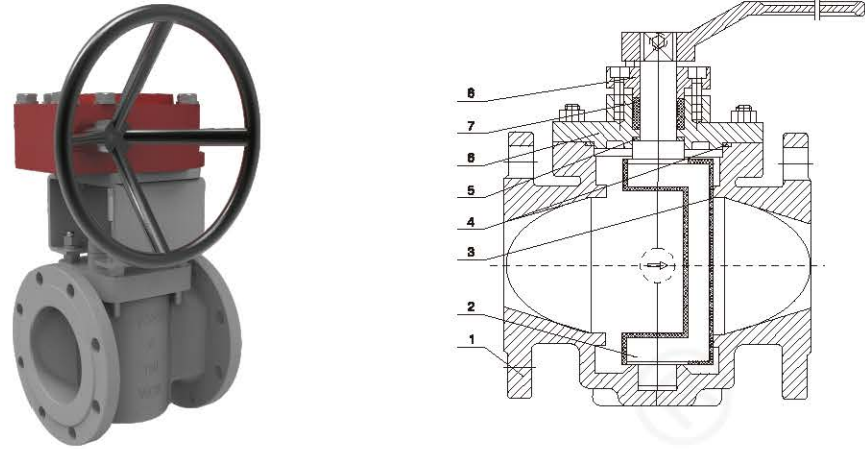

◎特征 Features

- 1、双偏心设计，低摩擦开启和关闭，确保零泄漏。
- 2、含镍=90%，3mm厚的堆焊阀座，或高性能树脂阀座，能满足多种耐腐蚀要求。
- 3、V型组合密封圈，可在不卸下操作机的情况下进行更换。
- 4、密封胶加注口设计，可延长阀门使用周期。
- 5、阀轴承为自润滑材料，无须加润滑脂，对阀轴磨损很小。
- 6、旋塞体模压热包胶，无橡胶脱落和冲刷腐蚀的担忧。
- 7、阀盖和阀体用O形圈密封，螺栓数量减少，方便维修。
- 8、理想的线性曲线，可作为调节阀使用。
- 9、提供阀门进出口压力表接头，方便用户控制和测定流量。
- 10、直通流道、圆柱形阀体设计。沉积物不容易堆积。
- 11、开度显示和开度记忆，方便用户操作。
- 12、可配置手动、电动、气动操作机。

1. Eccentric design, lower friction, zero leakage.
2. Welded-in stainless steel, nickel or resin seat can meet corrosion resistance requirements of various medium.
3. V type sealing ring can be changed on line without disassembling the operator.
4. Self-lubricated bearing provides very easy operation and low operation wearing.
5. Ductile iron plug wholly covered with rubber for drip-tight shut off assures excellent erode and corrosion resistance.
6. O-ring seals provide easy maintenance.
7. Linear characteristic can be used for throttling purpose.
8. Straight through flow design and columniform body can meet max. flow capacity requirements without deposits.
9. Opening indication provides easy operation.
10. Available for manual, pneumatic and electric actuator operation.

◎主要零件材料 Material of main parts

序号NO.	名称 Part name	材质 Material
1	阀体 Body	ASTM A216-WCB ASTM A351-CF8,CF8M,CF3,CF3M
2	旋塞 Plug	ASTM A216-WCB ASTM A351-CF8,CF8M,CF3,CF3M
3	阀座 Seat	不锈钢, 镍合金或树脂 Stainless steel, nickel, resin
4	O型密封圈 O-ring	橡胶 EPDM, NBR
5	轴承 Bearing	自润滑材料 Self-lubricated material
6	阀盖 Cover	ASTM A216-WCB ASTM A351-CF8,CF8M,CF3,CF3M
7	V型密封圈 V-ring	橡胶 EPDM, NBR
8	压盖 Pressing plate	ASTM A216-WCB ASTM A351-CF8,CF8M,CF3,CF3M

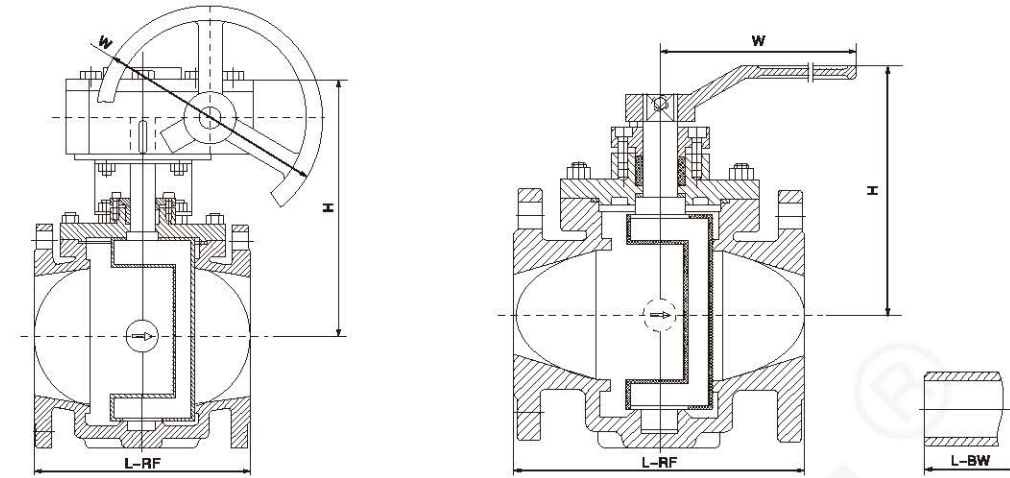

◎主要外形和连接尺寸 Main outline and connecting dimensions

单位Unit: mm

型号 Model		ZDAOX43-150														
压力等级 Pressure		150LB														
口径 Size	mm	15	20	25	32	40	50	65	80	100	125	150	200	250	300	350
	in	1/2	3/4	1	1 1/4	1 1/2	2	2 1/2	3	4	5	6	8	10	12	14
L-RF		108	117	127	140	165	178	190	203	229	254	267	292	330	305	381
L-BW		152	178	203	216	229	267	305	330	356	381	394	457	533	610	686
H		59	63	75	95	107	142	152	178	252	272	342	698	495	580	625
W		400	400	500	500	600	600	820	820	300	300	320	320	350	380	380
重量 (KG) Weight		10	12	14	17	19	21	29	33	48	75	98	125	171	230	370
型号 Model		ZDAOX43-300														
压力等级 Pressure		300LB														
口径 Size	mm	15	20	25	32	40	50	65	80	100	125	150	200	250	300	350
	in	1/2	3/4	1	1 1/4	1 1/2	2	2 1/2	3	4	5	6	8	10	12	14
L-RF		140	152	165	178	190	216	241	283	305	381	403	419	457	502	762
L-BW		152	178	203	216	229	267	305	330	356	381	457	521	559	635	762
H		59	63	75	95	107	142	152	178	252	272	342	398	495	580	625
W		400	400	500	600	600	820	1000	1000	300	300	320	320	350	380	380
重量 (KG) Weight		12	14	16	19	21	24	31	36	61	86	130	190	255	380	560
型号 Model		ZDAOX43-600														
压力等级 Pressure		600LB														
口径 Size	mm	15	20	25	32	40	50	65	80	100	125	150	200	250	300	350
	in	1/2	3/4	1	1 1/4	1 1/2	2	2 1/2	3	4	5	6	8	10	12	14
L-RF · BW		165	190	216	229	241	292	330	356	432	508	559	660	787	838	889
H		59	63	75	95	107	142	152	178	252	272	342	398	495	580	625
W		400	400	500	500	600	600	820	820	300	300	320	320	350	380	380
重量 (KG) Weight		14	16	18	20	24	29	35	47	91	129	210	210	660	920	1250
型号 Model		ZDAOX43-900														
压力等级 Pressure		900LB														
口径 Size	mm	15	20	25	32	40	50	65	80	100	125	150	200	250	300	350
	in	1/2	3/4	1	1 1/4	1 1/2	2	2 1/2	3	4	5	6	8	10	12	14
L-RF · BW		229	229	254	279	305	368	419	381	457	559	610	737	838	965	1029
H		59	63	75	95	107	142	152	178	252	272	342	398	495	580	625
W		400	400	500	600	600	820	1000	1000	300	300	320	320	350	380	380
重量 (KG) Weight		17	29	21	24	30	37	44	65	110	160	255	380	810	1050	1460

注：四寸及以上为蜗轮操作 4" or above with worm gear

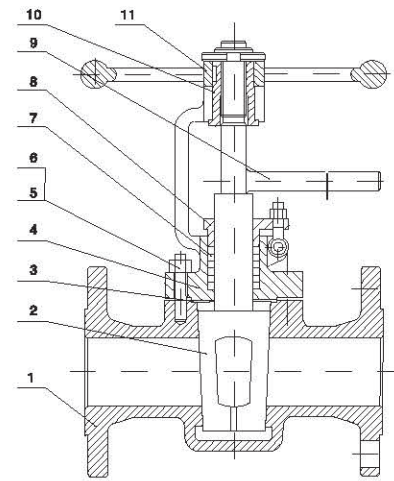

◎主要零件材料 Material of main parts

序号NO.	名称 Part name	材质 Material
1	阀体 Body	ASTM A216-WCB ASTM A351-CF8,CF8M,CF3,CF3M
2	塞子 Plug	ASTM A182-Gr.F6a ASTM A182-F22 ASTM A182-F304,F316,F321,F304L,F316L
3	垫子 Gasket	柔性石墨+不锈钢 Flexible graphite+stainless steel、 PTFE
4	阀盖 Cover	ASTM A216-WCB ASTM A217-WC1,WC6,WC9,C5 ASTM A351-CF8,CF8M,CF3,CF3M
5	螺栓 Bolt	ASTM A193-B7,A193-B8,A193-8M
6	六角螺母 Nut	ASTM A194-2H,A194-8,A194-8M
7	填料 Packing	柔性石墨 Flexible、 PTFE
8	填料压盖 Gland	ASTM A216-WCB ASTM A217-WC1,WC6,WC9,C5 ASTM A351-CF8,CF8M,CF3,CF3M
9	手柄 Wrench	ASTM A216-WCB ASTM A351-CF8,CF8M,CF3,CF3M
10	阀杆螺母 Yoke nut	铜合金 ZQA19-4
11	手轮 Handwheel	ASTM A536 Gr.60-40-18 ASTM A216-WCB

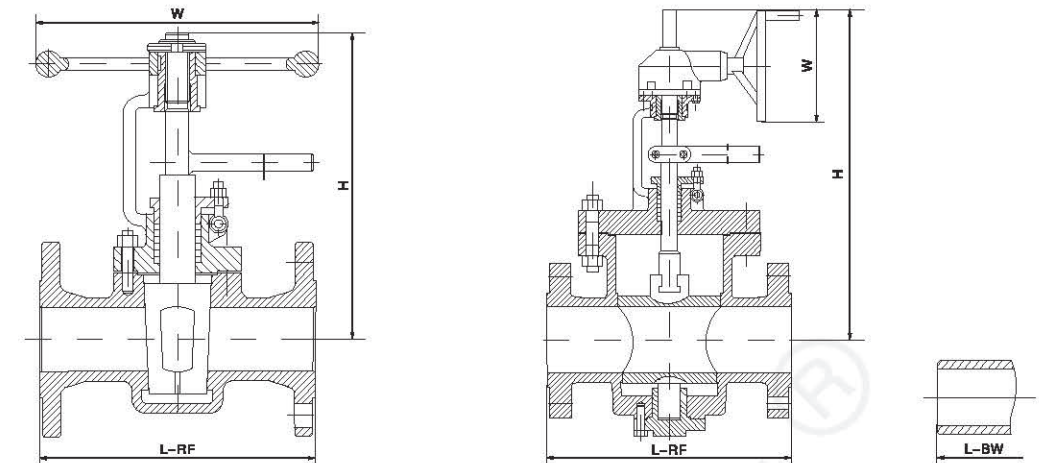

◎主要外形和连接尺寸 Main outline and connecting dimensions

单位Unit: mm

型号 Model	ZDAOX43-150															
压力等级 Pressure	150LB															
口径 Size	mm	15	20	25	32	40	50	65	80	100	125	150	200	250	300	350
	in	1/2	3/4	1	1 1/4	1 1/2	2	2 1/2	3	4	5	6	8	10	12	14
L-RF	108	117	127	140	165	178	190	203	229	254	267	292	330	305	381	
L-BW	152	178	203	216	229	267	305	330	356	381	394	457	533	610	686	
H	190	195	225	260	280	310	340	395	435	470	535	590	630	680	720	
W	120	140	140	180	200	220	260	280	300	340	400	450	450	500	500	
重量 (KG) Weight	9	10	11	17	19	23	25	32	55	82	98	130	178	250	380	
型号 Model	ZDAOX43-300															
压力等级 Pressure	300LB															
口径 Size	mm	15	20	25	32	40	50	65	80	100	125	150	200	250	300	350
	in	1/2	3/4	1	1 1/4	1 1/2	2	2 1/2	3	4	5	6	8	10	12	14
L-RF	140	152	165	178	190	216	241	283	305	381	403	419	457	502	762	
L-BW	152	178	203	216	229	267	305	330	356	381	457	521	559	635	762	
H	190	195	225	260	280	310	340	395	435	470	535	590	630	680	720	
W	120	140	140	180	200	220	260	280	300	340	400	450	450	500	500	
重量 (KG) Weight	10	12	14	19	21	28	34	39	75	95	135	200	255	415	650	
型号 Model	ZDAOX43-600															
压力等级 Pressure	600LB															
口径 Size	mm	15	20	25	32	40	50	65	80	100	125	150	200	250	300	350
	in	1/2	3/4	1	1 1/4	1 1/2	2	2 1/2	3	4	5	6	8	10	12	14
L-RF·BW	165	190	216	229	241	292	330	356	432	508	559	660	787	838	889	
H	190	195	225	260	280	310	340	395	435	470	535	590	630	680	720	
W	120	140	140	180	200	220	260	280	300	340	400	450	450	500	500	
重量 (KG) Weight	13	14	19	23	25	32	40	55	105	139	300	440	730	1150	1570	
型号 Model	ZDAOX43-900															
压力等级 Pressure	900LB															
口径 Size	mm	15	20	25	32	40	50	65	80	100	125	150	200	250	300	350
	in	1/2	3/4	1	1 1/4	1 1/2	2	2 1/2	3	4	5	6	8	10	12	14
L-RF·BW	229	229	254	279	305	368	419	381	457	559	610	737	838	965	1029	
H	190	195	225	260	280	310	340	395	435	470	535	590	630	680	720	
W	120	140	140	180	200	220	260	280	300	340	400	540	450	500	500	
重量 (KG) Weight	16	17	26	30	33	39	50	70	137	181	397	590	860	1470	1880	

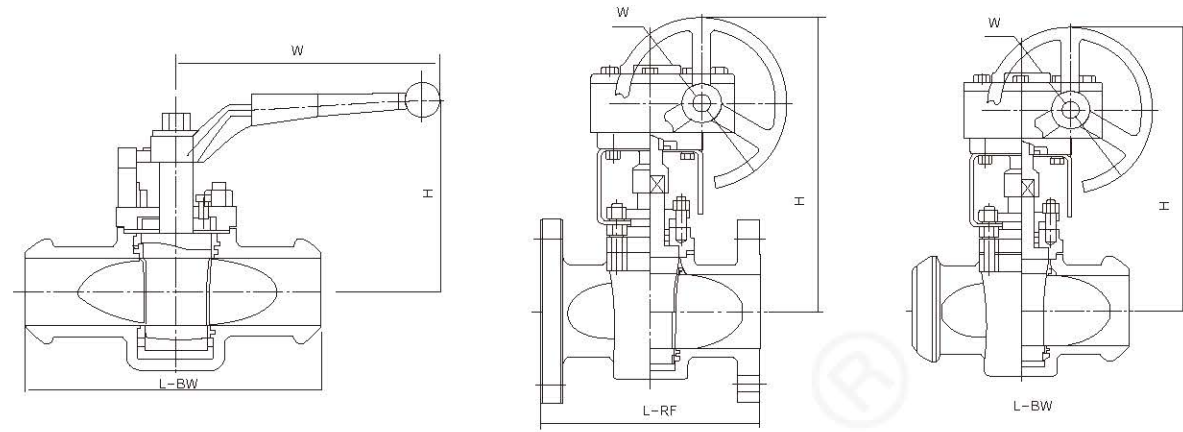

◎主要外形和连接尺寸 Main outline and connecting dimensions

单位Unit: mm

型号	ZDDX43-16														
压力等级	PN16														
口径	15	20	25	32	40	50	65	80	100	125	150	200	250	300	350
L-RF·BW	130	150	160	180	200	290	290	310	350	400	480	600	730	850	980
H	150	155	160	180	190	220	220	230	380	460	520	580	620	680	740
W	300	300	300	350	400	500	500	550	300	300	320	320	350	380	380
重量 (Kg)	9	10	11	13	14	19	23	27	43	62	75	155	222	390	580
型号	ZDDX43-25														
压力等级	PN25														
口径	15	20	25	32	40	50	65	80	100	125	150	200	250	300	350
L-RF·BW	130	150	160	180	200	290	290	310	350	400	480	600	730	850	980
H	150	155	160	180	190	200	220	230	380	460	520	580	620	680	740
W	300	300	300	350	400	500	500	550	300	300	320	320	350	380	380
重量 (Kg)	10	11	13	15	17	22	31	55	77	88	190	190	235	399	630
型号	ZDDX43-16														
压力等级	PN16														
口径	15	20	25	32	40	50	65	80	100	125	150	200	250	300	350
L-RF·BW	130	150	160	180	200	290	290	310	350	400	480	600	730	850	980
H	190	195	225	260	280	310	340	395	435	470	535	590	630	680	720
W	120	140	140	180	200	220	260	280	300	340	400	450	450	500	500
重量 (Kg)	14	17	22	25	29	34	43	50	94	123	170	291	430	625	875
型号	ZDDX43-40														
压力等级	PN40														
口径	15	20	25	32	40	50	65	80	100	125	150	200	250	300	350
L-RF·BW	130	150	160	180	200	290	290	310	350	400	480	600	730	850	980
H	190	195	225	260	280	310	340	395	435	470	535	590	630	680	720
W	120	140	140	180	200	220	260	280	300	340	400	450	450	500	500
重量 (Kg)	12	14	18	21	24	29	33	39	75	103	146	251	337	521	720

注: 四寸及以上为蜗轮操作

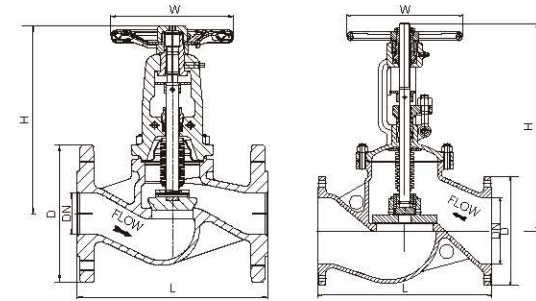

◎产品特点 Product features

1. 波纹管是波纹管阀门的关键组件, 采用自动滚焊, 焊在阀瓣与阀杆上, 确保阀杆部件100%零泄露。
 2. 双密封设计(波纹管+填料)。波纹管形成第一道金属密封防止泄漏, 如果波纹管失效, 填料可以提供第二道密封。
 3. 堆焊阀座, 即使在恶劣工况下, 也能确保可靠的密封。
 4. 人体工程学设计手轮, 使用寿命更长, 操作轻松便捷且安全可靠。
1. bellows is the key component of bellows valve. Automatic roll welding is adopted to weld on the valve disc and valve stem to ensure 100% zero leakage of valve stem parts.
 2. double seal design (bellows + packing). The bellows form a first metal seal to prevent leakage. If the bellows fails, the packing can provide a second seal.
 3. the welding of the valve seat can ensure reliable sealing even under severe conditions.
 4. ergonomic handwheel has longer service life, easy and convenient operation and safe and reliable.

◎主要性能规范 Main performance specification

设计标准 Design criteria: DIN EN 13709:2003 对焊连接 Butt welding connection: DIN EN 12627
 结构长度 Structure length: DIN EN 558-1:1995 试验与检验 Butt welding connection: DIN EN 12266:2003
 连接法兰 Connecting flange: DIN EN 1092-1:2002

◎主要外形尺寸和连接尺寸 Main shape size and connection size

单位Unit: mm

PN16																
口径 DN	15	20	25	32	40	50	65	80	100	125	150	200	250	300	350	400
总长 L RF/BW	130	150	160	180	200	230	290	310	350	400	480	600	730	850	980	1100
外圆 D	95	105	115	140	150	165	185	200	220	250	285	340	405	480	520	580
手轮 W	140	140	160	160	180	200	220	250	300	350	400	450	550	600	700	700
中心高 H	192	192	207	207	245	253	295	328	385	427	480	672	775	852	1005	1140
重量(kg)	4	4.8	3.8	7.8	9.5	12.5	17	22	36	52	81	135	240	305	510	740
行程	8	8	10	10	12	15	17	22	28	34	40	60	75	85	100	110
流量 Kvs(m³/h)	4.2	7.4	12	19	30	47	77	120	188	285	410	725	1140	1660	2230	2950
PN25																
口径 DN	15	20	25	32	40	50	65	80	100	125	150	200	250	300	350	400
总长 L RF/BW	130	150	160	180	200	230	290	310	350	400	480	600	730	850	980	1100
外圆 D	95	105	115	140	150	165	185	200	220	270	300	360	425	485	555	620
手轮 W	140	140	160	160	180	200	220	250	300	350	400	450	550	600	700	700
中心高 H	192	192	207	207	245	253	295	328	385	427	480	672	775	852	1005	1140
重量(kg)	4	4.8	5.8	7.8	9.5	12.5	17	22	37	53	82	140	245	315	530	780
行程	8	8	10	10	12	15	17	22	28	34	40	60	75	85	100	110
流量 Kvs(m³/h)	4.2	7.4	12	19	30	47	77	120	188	285	410	725	1140	1660	2230	2950
PN40																
口径 DN	15	20	25	32	40	50	65	80	100	125	150	200	250	300	350	400
总长 L RF/BW	130	150	160	180	200	230	290	310	350	400	480	600	730	850	980	1100
外圆 D	95	105	115	140	150	165	185	200	235	270	300	375	450	515	580	660
手轮 W	140	140	160	160	180	200	220	250	300	350	400	450	550	600	700	700
中心高 H	192	192	207	207	245	253	295	328	385	427	480	672	775	852	1005	1140
重量(kg)	4	4.8	5.8	7.8	9.5	12.5	17.5	23	38	54	83	142	260	320	560	820
行程	8	8	10	10	12	15	17	22	28	34	40	60	75	85	100	110
流量 Kvs(m³/h)	4.2	7.4	12	19	30	47	77	120	188	285	410	725	1140	1660	2230	2950